

Low-intensity L810 Solar Aviation Obstruction Light

AH-LS-A



AH-LS/A is a self-contained obstruction light which consist of solar panel, battery and lamp. There is no need for external power input. The vertical degree of the solar panel is adjustable to ensure it could get the most sunlight in different area.

It is designed for marking top of obstacle that do not exceed 45 meters in height.

Compliance

- CAO Annex 14 Volume 1, Sixth edition, 2013, table 6.3 Low Intensity Type A / B Obstruction Light
- FAA L-810

Features

Electrical

- LED as light source, life experience >100,000hours

Physical

- With bird needle to prevent bird drop
- UV & vibrations protected polycarbonate lens for converging light
- Powder coated die casting aluminum base, light fastness, resist snow and rain
- Battery box made of corrosion resistant 304 stainless steel
- Self-contained without external power supply, Cable cost saving & cabling job saving, No wiring job, nice & easy installation
- Solar panel vertical degree is adjustable

System design

- Solar panel as sensor(Photo diode) for day & night working mode (dusk to dawn mode)
- ON/OFF button under base make local control easy
- Steady/Flashing(20fpm) adjustable switch available
- Solar panel angel is adjustable (Vertical 15-90°)

Optional

- GSM cellphone monitoring
- Infrared LED for pilot using NVG(Night Vision Goggles)
- Remote control ON/OFF

Application

- AH-LS-A solar low-intensity light is specialized used on the top of the High Chimney, Telecommunication tower, Wind Turbine where there is no cable power supply and those facilities which have high requirements on lightning protection.
- Used alone on the top of obstacle which height is less than 45meter



APPLICATION



Low-intensity L810 Solar Aviation Obstruction Light

AH-LS-A

Dimension(mm)

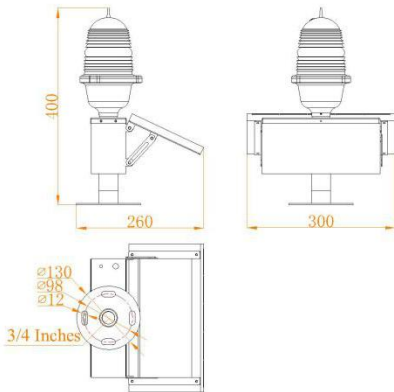

Installation

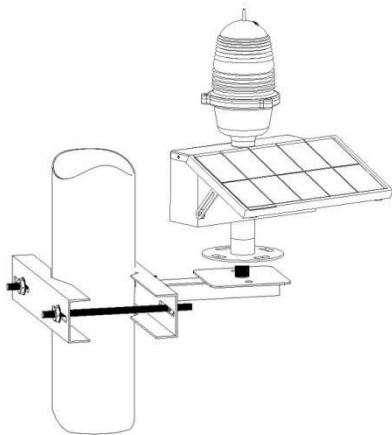

(Mounting bracket is charged separately,
and size is customized)

SPECIFICATIONS

AH-LS-A Low-intensity L810 Solar Aviation Obstruction Light

Light Characteristics

Light Source	LED
Emitting Color	Red
Intensity(cd)	≥32.5cd
Horizontal Output(degrees)	360
Vertical Divergence(degrees)	≥10
Flash Characteristics	Steady/Flashing(20fpm) adjustable
Operation Mode	Dusk-to-Dawn operation
LED Life Experience(hours)	>100,000

Electrical Characteristics

Operating Voltage	12
Circuit Protection	Integrated

Solar Characteristics

Solar Module Type	Mono crystalline Silicon
Output(watts)	12
Charging Regulation	Microprocessor controlled

Battery Characteristics

Battery type	Lithium ion battery
Nominal Voltage (V)	12
Battery Service Life	Average 3 years
Battery Capacity(AH)	9
Autonomy (hours)	Steady: 60, Flashing: 120

Physical Characteristics

Lamb Body Material	UV protected Polycarbonate
Base Material	Stainless steel 304
Installation Size	98×98×Ø12 & 3/4inch thread
Overall Size (mm)	260×300×400
Weight(kg)	3
Product Life Expectancy	Average 5 years

Environmental Factors

Ambient Temperature(°C)	-55~70
Humidity	0~90%
Wind Speed	80m/s
Waterproof	IP65

Compliance

ICAO	Annex 14 Volume 1, 'Aerodrome Design and Operations' Sixth edition July 2013, table 6.3 Low-intensity Type A/B Obstacle Light
FAA	L-810

Optional

GSM cellphone monitoring
NVG - compatible infrared (IR) LED